

FOOD pre-scrapers

8600

FOODS PRE-SCRAPER WITH FDA-APPROVED POLYURETHANE
 – Effective cleaning of drums in the food industry.

The Food scraper 8600 is an FDA-approved pre-scrapers designed for pulleys from $\varnothing 100 - \varnothing 200$ mm. The scraper blade is molded of durable polyurethane, and is approved for food usage; the remaining parts are of stainless steel and acid-resistant materials. The blade is flexible and adapts to the shape of the conveyor belt.

Our unique spring lever ensures that the correct pressure is maintained against the belt which simplifies service work and reduces maintenance. The pressure on the belt is steplessly regulated with a torsion spring installed in the square tubing.

The pre-scrapers is positioned against the drive pulley immediately below the flow of material.



Vendig also supplies sheeting PEHM500 which is FDA-approved to be used as cutting boards in the food industry.

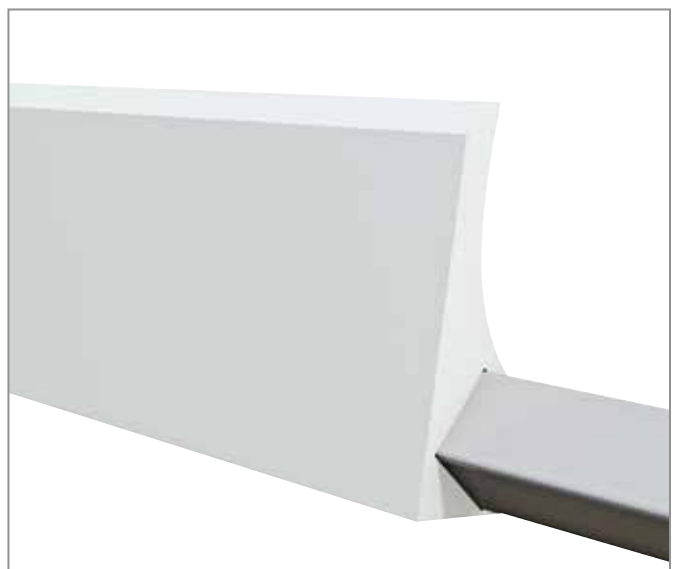
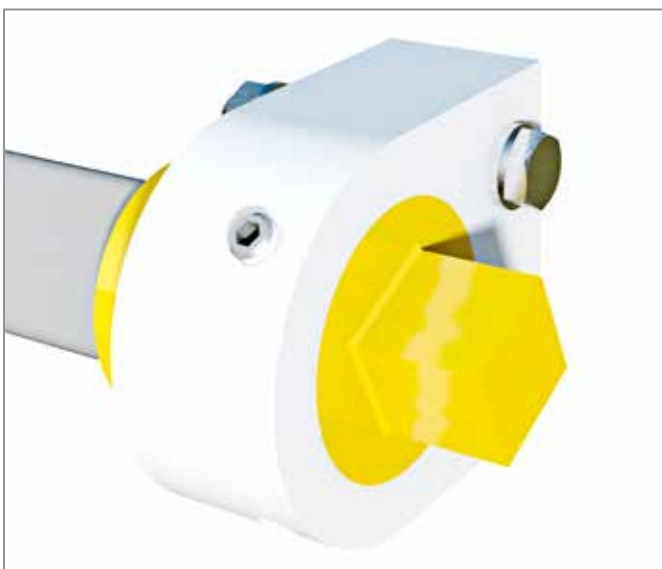

Product information 8600

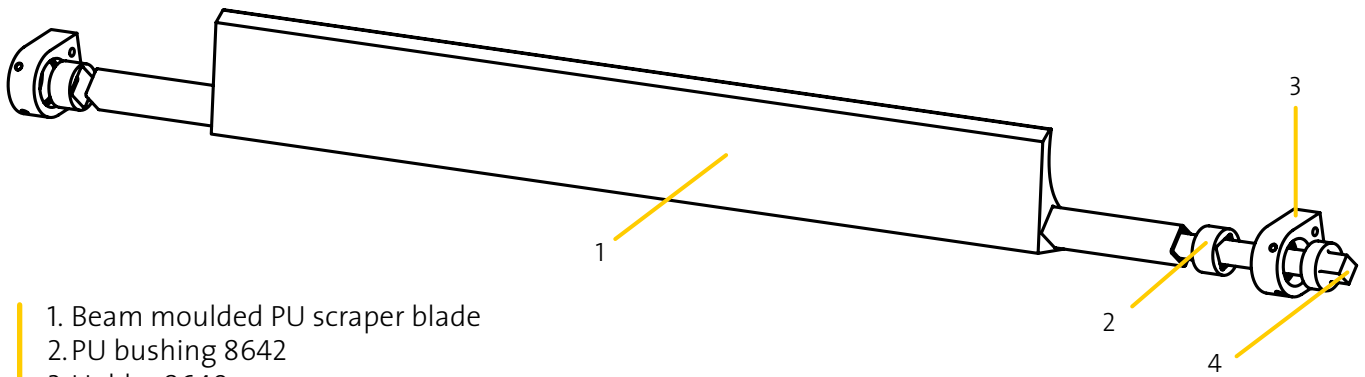

- 1. Beam moulded PU scraper blade
- 2. PU bushing 8642
- 3. Holder 8640 or Holder 8641
- 4. Torsion spring 8643

All steel parts are stainless and acid-proof.
 From B-B 600 the scraper is delivered with dual torsion springs.

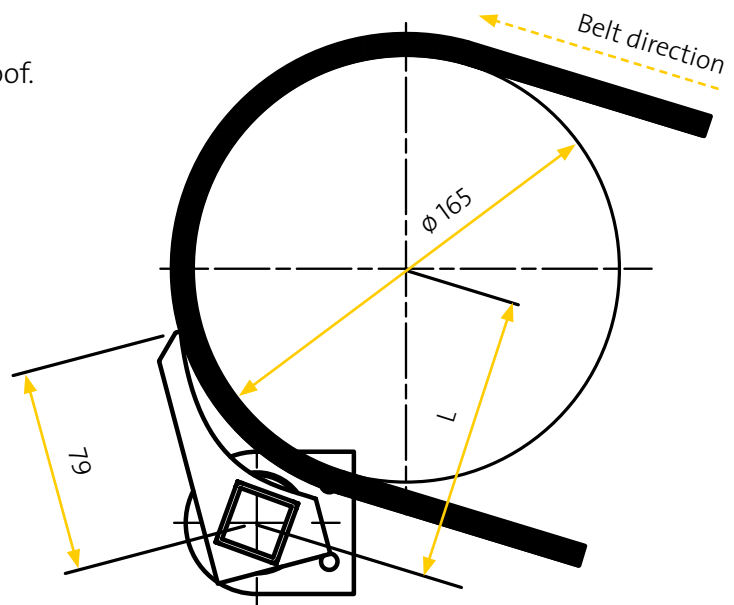

ART.NO.	B-W	SCRAPER WIDTH	BEAM LENGTH
8603	300	300	550
8604	400	400	650
8605	500	500	750
8606	600	600	850
8607	700	700	950
8608	800	800	1050
8609	900	900	1150
8610	1000	1000	1250
8611	1100	1100	1350
8612	1200	1200	1450