

Picture 1

1. Scraper blade	2924-2938
2. Aluminium cassette	9940
3. Balk (varierande längd)	9964-9976
4. Fästen hö, vä	9980, 9981
5. Hållare H	8382
6. PU-bussning	8383
7. Balkklämma	9161
8. Fjädrfäste	9182
9. Fjädrande hävarm, komplett	9178
10. M6 x50mm bult (ingår i hållare H artikeln)	

## FITTING INSTRUCTIONS **SIRIUS UNO 2900**

Sirius belt scrapers are all made of durable polyurethane and mounted in a removable cassette. Sirius UNO 2900 pre-scraper is durable and designed industry with high demands on cleanliness. The blade will shape itself according to the conveyor belt and the form of drum. The worn out blade can be exchanged without tools.

### CONDITIONS FOR OPTIMUM OPERATION OF SIRIUS

To achieve the best cleaning results of the conveyor belt, the following conditions must be met:

- The belt cleaner shall **not** be fitted to chevron belts or belts with mechanical joints.
- The conveyor belt must be free of damage. The belt may otherwise get caught on the scraper blade (1), resulting in a damage on either belt or belt cleaner.
- Max. belt speed: 2.8 m/s
- Max. temperature: + 50°C in wet environments (ambient temperature + frictional heat)
- Max. temperature: + 85°C in dry environments (ambient temperature + frictional heat)

#### CAUTION!

Lockout and Tagout! Always turn off the conveyor belt before maintaining, adjusting or installing the product to make sure that the belt cannot start while the work is in progress.

### WARRANTY

The product is covered under 24months warranty from time of purchase. For questions or claims, please contact our customer service. Damage to the belt cleaner caused by incorrect handling or incorrect installation will not be considered subject to guarantee. Vendigo will not be considered responsible for consequences or damage on other equipment or for

## ASSEMBLING

Turn off the belt conveyor. Lockout and Tagout!

Picture 2

Place the belt cleaner against the drive pulley with the center of the beam (3) at distance L from the center of the drive pulley, see picture 2.

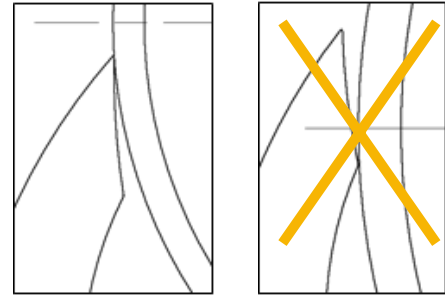

How high to place the top of the scraper blades is determined by the gradient of the conveyor, the speed of the belt and the space available around the drive pulley. The belt cleaner is to be mounted just below the material flow when the conveyor is running. If the material flow hits the scraper blade (1) the tear will shorten its lifespan dramatically. If that is the case, lower the belt cleaner slightly until the material flow passes the belt cleaner.

It is important that the scraper blade (1) is fitted with the correct angle to the drive pulley's surface, see picture 2.

- Assemble holder H (5), PU-bushing (6 and hose clamp (7) to the beam (3). Assemble the parts in the same order on both sides of the beam.
- Make two mounting brackets and weld these to the frame of belt conveyor where the holder H (5) should be fitted. The brackets shall each have two  $\varnothing 11$  mm holes, c-c 40mm and can be made from flat iron for example.
- Weld the mounting plates in the conveyor frame near the drive pulley, so that the holder H (3) can be assembled to the mounting bracket with distance (L) to the center of the drive pulley.
- Screw the holders H (5) to the mounting plates. Ensure that the L dimension is met and that the scraper blade in the scraper blade (1) is connecting to the conveyor belt in correct angle, (see picture 2).
- Center the belt cleaner sideways to the conveyor belt and lock the beam laterally with the hose clamps (7). Cut the beam (3) to the suitable length at both ends.
- Assemble the spring lever arm (9) to the lever arm fixing (8). Make sure that the end of the spring lever arm locks in the socket of the fixing (8).
- Insert the lever arm fixing (8) into the end of the beam (3). Drill a hole ( $\varnothing 7$  mm) right through the beam and lock the lever arm fixing (9) using an M6 x 50 mm bolt (10).
- Weld the toothed washer to the conveyor frame. Tension the spring lever arm (9) and hook the snap hook onto the toothed washer. Find the optimal pressure by adjusting, see below.

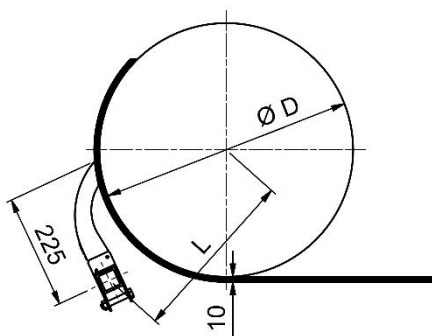

Picture 3

Drum pulley	L
$\varnothing 320$	289
$\varnothing 400$	313
$\varnothing 500$	350
$\varnothing 630$	405
$\varnothing 800$	480
$\varnothing 1000$	578

## ADJUSTMENTS

When all the parts are assembled according to the instructions above, turn the conveyor belt on to adjust the settings.

Find the optional pressure of the belt cleaner by eliminating noise, eliminating vibrations and watch how the cleaning performance changes when adjusting pressure.

In regular operation of the belt conveyor, vibrations and noise from the belt cleaner is a sign that adjustments is needed. Vibrations sometimes occur when the belt is running without material so keep the stand by-time to a minimum. Vibrations also occur when the belt has a sticky coating, for example of resin, keeping the belt clean is of essence. Vibrations can eventually cause fracture damages in the beam and must be eliminated. To reduce vibration and noise in other cases, follow the steps below. Remember to always turn off the belt conveyor before adjustments are made.

Change the angle of the blades against the belt a few degrees

Change the pressure of the belt cleaner against the belt.

Make heavier, more sturdy mounting brackets for attaching to the conveyor frame.

Increase the stability of the beam by fitting a small weight or a cantilever to the beam (3).

## MAINTENANCE

Inspect and clean the belt cleaner regularly, as a suggestion once a week. When 110 mm of the scraper blade remains change it. Measure the height on the inside towards the belt.

When noise or vibration occurs, adjust the settings immediately.

### REPLACING THE SCRAPER BLADE

Change the scraper blade (1) by removing the snap hook from the toothed washer and loosen the tension on the belt cleaner. The blade can be snapped out of the aluminum profile (2) or it can be exchanged through removing the whole cassette.

It is snapped out by holding one outer edge and prying/ wiggle the other end out of the profile and then snapping continuously against the edge you are holding. If the blade is worn down, you can use a tool in the holes in the blade to get lever to snap out of the blade with.

To release the cassette which is fixed with brackets (4), loosen the bolt under the beam and knock out the bracket on one side to release the cartridge from the beam. The new scraper blade can now be snapped into the cassette. Once everything is reassembled, pre-tension the scraper again and lock the chain back to the toothed washer.

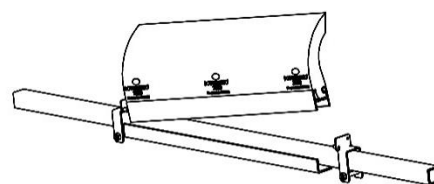
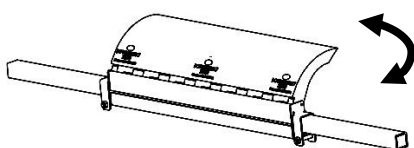



The scraper blade can either be snapped on and off (left picture) or the cassette could be taken out completely (right picture)